

Hygro-Thermograph

Instruction for use 16.46.Q



1. Range of application

The Hygro-Thermograph measures and records both the relative humidity and the air temperature of the surrounding atmosphere. The recording drum is driven with utmost precision either by a manual spring clockwork mechanism or by a battery-operated quartz clockwork (see models available). Either H or K humidity measuring elements can be used depending on the general on-site operating conditions.

H measuring elements are suitable for taking measurements in normal to very moist air at temperatures below and above 0°C.

K measuring elements are designed for use in normal to dry air in the temperature range above 0°C and require no maintenance.

Typical applications include environmental monitoring in computer rooms, factories, warehouses, offices, laboratories, nurseries, museums and galleries but they can also be used in meteorological measuring stations.

2. Set-up and mode of operation

The clockwork and the columns with the humidity measuring element and the temperature measuring element are mounted to a base plate. A transparent inverted cover made of UV-resistant polycarbonate is used for protection of the entire system. The measuring elements react promptly thanks to large ventilation openings in the direction of measurement.

Humidity is measured by a hair (H) or by a synthetic (K) measuring element. These measuring elements consist of several hairs or fibres whose lengths change when the humidity changes. This change in length is recorded by a felt pen onto a paper recording strip via a system of levers. The measurement accuracy indicated for the H measuring element applies to regenerated measuring elements in decreasing humidity.

Temperature is measured by a high quality, aged bimetallic measuring element which has been bent to form a ring. The radius of the measuring element changes when the temperature changes. This change in radius is likewise recorded on the recording strips. The rotation of the drum allows time-dependent registration.

3. Models available

1.0670.xx.xxx	1 day / 7 days switchable	Spring clockwork -35 ... + 80 °C
1.0674.xx.xxx	14 days / 31 days switchable	Spring clockwork -35 ... + 80 °C
16.46.Q	1 day / 7 days / 31 days switchable	Quartz clockwork -20 ... + 60 °C

Humidity measuring range:

...10...	H (10...100 % rel.h. ; -35...+80 °C)
...12...	K (0...100 % rel.h. ; 0...+80 °C)

Temperature measuring range:

...000	-35 ... +45 °C	Graduation 1 °C
...005	-20 ... +60 °C	Graduation 1 °C
...011	-10 ... +50 °C	Graduation 1 °C
...014	0 ... +40 °C	Graduation 0,5 °C
...017	0 ... +80 °C	Graduation 1 °C



P.O. Box 4, 6987 ZG Giesbeek
Nijverheidsstraat 30,
6987 EM Giesbeek,
The Netherlands
T +31 313 880200
F +31 313 880299
E eijkelkamp@eijkelkamp.com
I <http://www.eijkelkamp.com>

4. Technical Data

Humidity

Measuring range	: 10 ... 100 % rel. humidity "H"
	0 ... 100 % rel. humidity "K"
Graduation	: 5 % rel. humidity
Temp. working range	: -35 ... +70°C "H"
	0 ... +80°C "K"
Accuracy	: ± 2 % rel. humidity "H"
	± 3 % rel. humidity "K"

Temperature

Measuring range	: -35 ... +80°C (see models available)
Graduation	: 1°C resp. 0,5°C (see models available)
Accuracy	: ± 1 % of the measuring range

Spring clockwork mechanism

Recording time	: 1 day / 7 days resp. 14 days / 31 days
Thrust	: 11,45 mm/h.; 40,01 mm/day resp. 20 mm/day; 9 mm/day
Temperature range	: -35 ... +80 °C
Gear accuracy	: ± 60 s/day at 20°C in accordance with DIN 8300

Quartz clockwork

Recording time	: 1 day / 7 days / 31 days
Thrust	: 11,45 mm/h.; 40,01 mm/day; 9 mm/day
Temperature range	: - 20 ... + 60 °C
Gear accuracy	: ± 2 s/Tag
Battery capacity	: > 1 year at 20°C (Mignon battery 1,5 V)
Battery type	: Type LR6

Clockwork drum	: S 93 x 186 acc. to. DIN 58658
Recording strip	: acc. to. DIN 16232
Recording width	: 2 x 82 mm
Weight	: 2,1 kg

Scale drawing

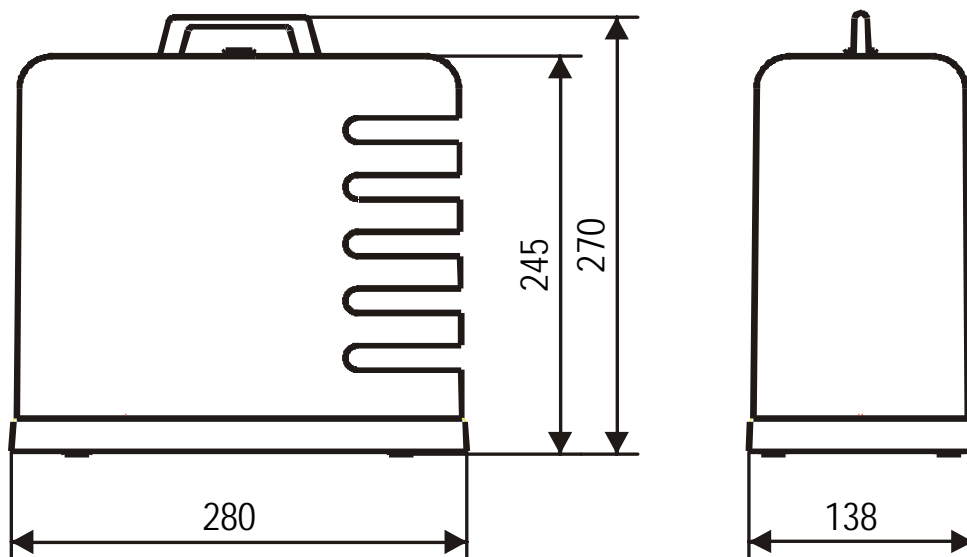

5. Preparation for Use

For easy operation, the inverted drum of the quartz clockwork mechanism is simply set without any screws onto the central shaft. That is why the opened instrument may never be transported or carried on the inverted drum.

Unscrew the knurled screw, remove the inverted cover and remove the foam rubber (used for transport) from the clockwork. Press the switch-off lever to the right to raise the recording pens from the recording strip.

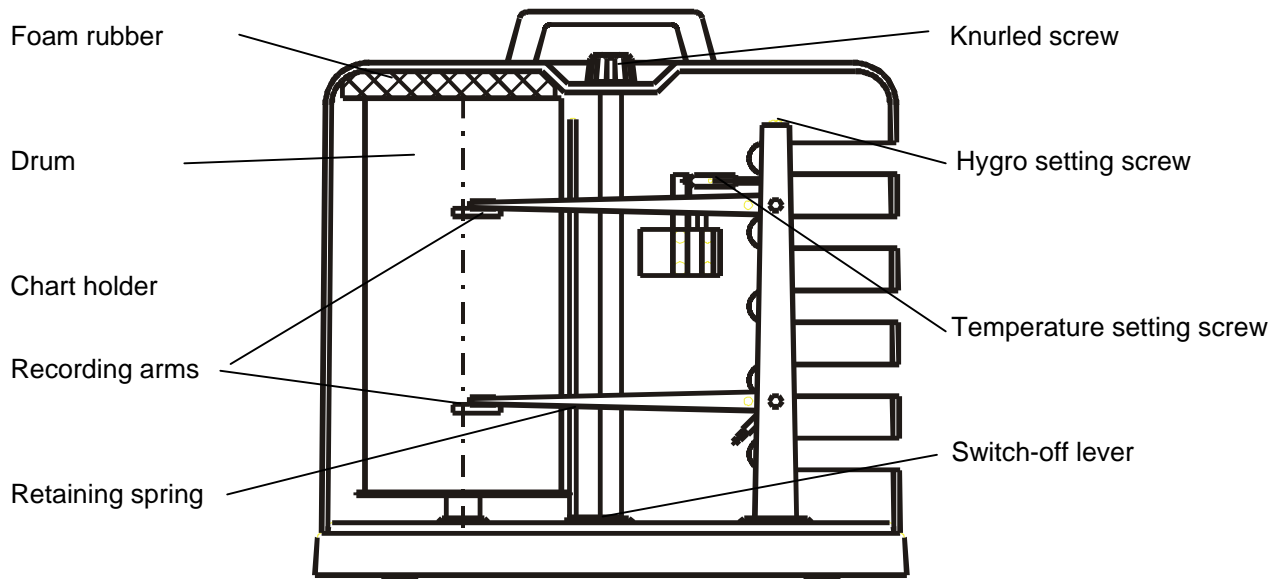

Setting the desired recording time

For instruments with a spring clockwork mechanism, unscrew the winding key by turning it towards the right and remove the inverted drum from the drive mechanism. The desired recording time can be set by changing the interchangeable gear wheel on the drum.

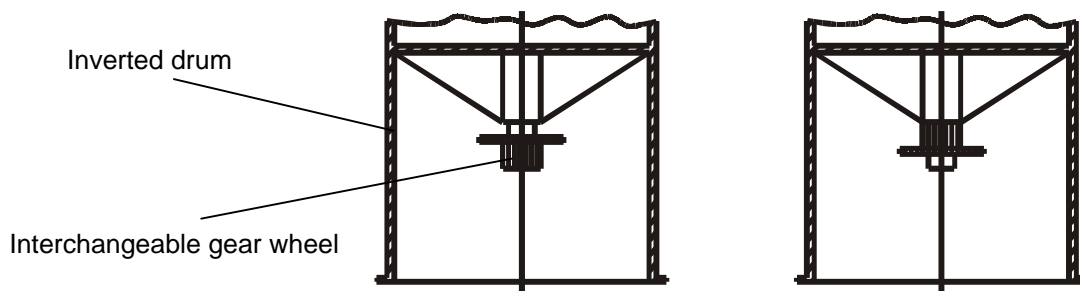

Order no.	Recording time	Recording time
1.0670.xx.xxx	1 day	7 days
1.0674.xx.xxx	14 days	31 days

Instrument 16.46.Q with quartz clockwork:

Remove the inverted drum from the drive mechanism and set the recording time with the red gear wheel by clicking it into place at the appropriate height. Make sure that the yellow gear wheel is properly engaged. Place the enclosed battery into the recess provided with the poles in the correct direction.

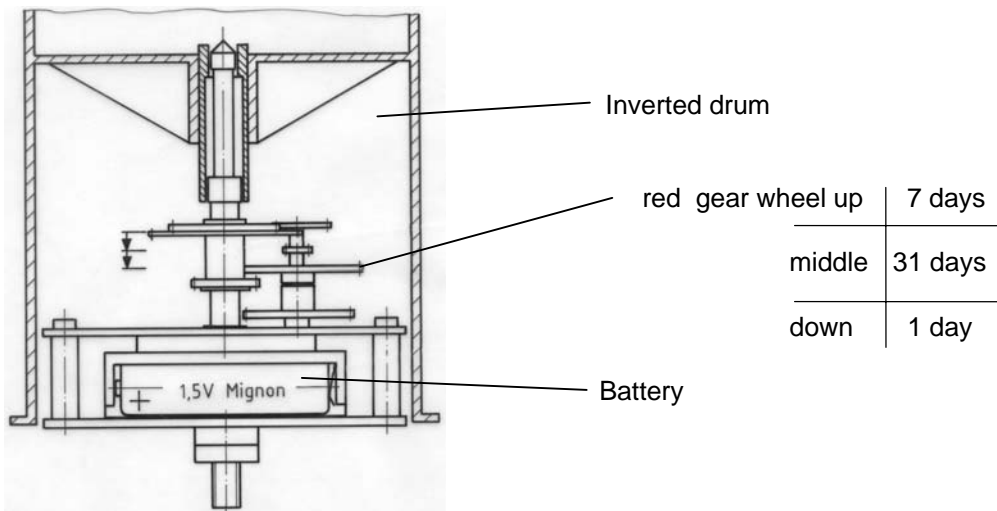

Place the recording strip onto the inverted drum (see 6.1 Changing the recording strip) and insert this onto the drive mechanism until it locks into place!

Remove the lower recording arm from the clamp bolt (transport safety device). Remove the tip protector from the felt pen. For instruments with a spring clockwork mechanism, wind the clockwork with the key in the drum, turning it to the left. Rotate the drum counter clockwise to the correct time. Close the hood and screw the knurled-head screws back into place. Press the switch-off lever to the right stop in order to lower the recording pens onto the recording strip.

6. Maintenance

6.1 Changing the recording strip

This should be done regularly at the time where the recording strip starts; for example if you are using a 7 day recording period, then change the strip every Monday morning. After swinging the recording arm forwards, raise the chart holder and remove the recording strip. Place the new recording strip onto the drum and fix it into position by inserting the chart holder. Make sure that the new recording strip fits snugly and smoothly against the lower edge of the drum. Rewind the clockwork mechanism every time you change the recording strip. Swing the recording arms back to their original position and rotate the drum counter clockwise to the correct time. The instrument is now ready for use.

Spare Recording Strips (1 set - 100 sheets), Order no. key

°C	Measuring element "H"				Measuring element "K"			
	1 day	7 days	14 days	31 days	1 day	7 days	14 days	31 days
-35/+45	205142	205086	205153	205169				
-20/+60	205143	205083	205158	205168				
-10/+50	205138	205092	205155	205166				
0/+40	205123	205094	205150	205160	205131	205097	205151	205161
0/+80	205126	205103	205280	205281	205134	205112	205282	205283

6.2 Changing the recording pens

Remove the recording pens carefully from the recording arms. Remove the tip protection from the new pen. Make sure that you do not touch the recording tip when you place the new pen into position.

Spare Recording pens (minimum order of 6) Order-No. 500 847

6.3 Regenerating the humidity measuring element

H-measuring elements dry out when the relative humidity is less than 60%. This results in an increase in the zero point of approximately 5% or more rel. humidity. At ca. 60% rel. humidity, maximum inaccuracy is reached in 3 weeks. This time is shorter when the humidity value is even lower. Accuracy can be restored by regeneration. Simply place the instrument in saturated air for some hours. At the conclusion of the regeneration process, check whether the measuring element has returned to 95% rel. humidity. This value can be set on the humidity setting screw.

Measuring elements which are located out-of-doors or in huts regenerate automatically because the central European climate is such that, particularly at night - humidities of 95% occur.

K-measuring elements do not degenerate and consequently do not have to be regenerated.

6.4 Checking the bimetallic setting

The accuracy of the bimetallic element is checked by carrying out a comparative measurement. In a temperature-constant room hang a precision mercury thermometer next to the Hygro-thermograph. Allow about 20 minutes adjustment time and then compare the temperature values. If a correction is necessary, do this with the aid of the temperature setting screw on the bimetallic element.

6.5 Static Charge

4. A static charge arises when the cover is rubbed thoroughly with a cloth; then the recording arms stick on the cover side. In order to avoid static charges it is recommended to clean the cover inside in regular intervals with the enclosed antistaticum.